

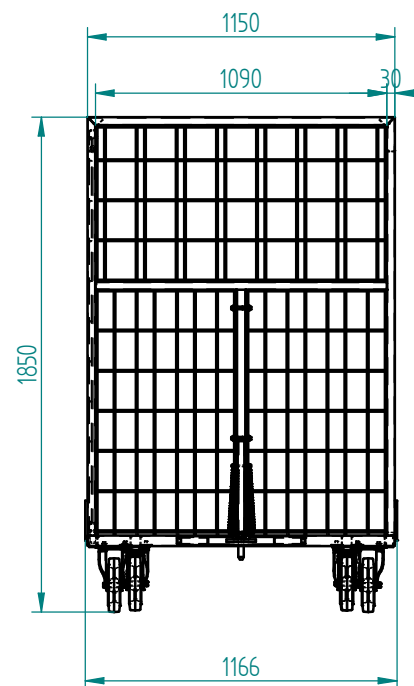

DIMENSIONS TOLERANCE	
TOLERANCE	+ -3 mm

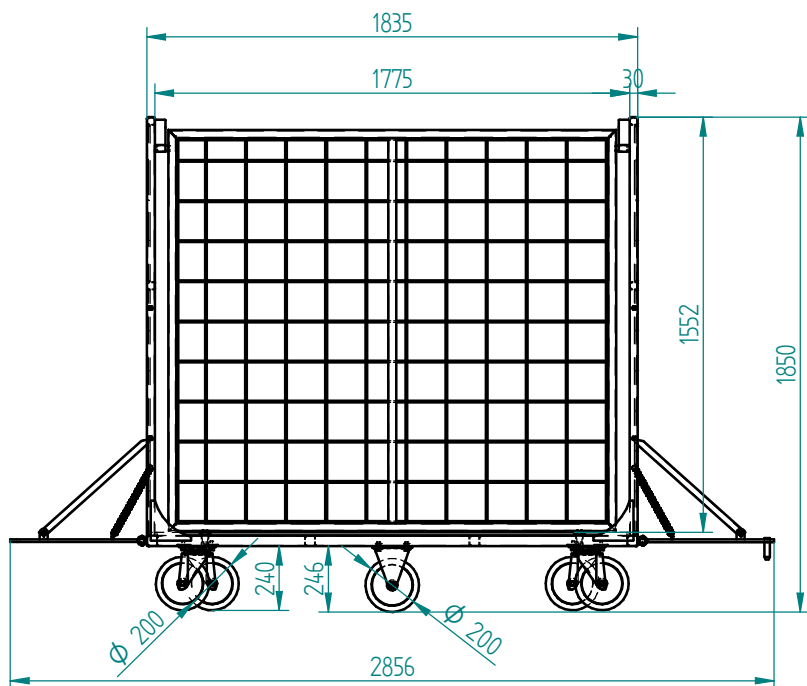

Numeracja malowana od nr 101 do 400  
Prawa strona wózka od przodu

PRODUCT DATA SHEET						
DIMENSIONS		MAX LOAD	LEVELS	CAPACITY	OPTIMAL TRANSPORT	
2856 X 1166 X 1850		500 kg	-	---	18 pcs. / Z	
Konstrukcje wykonać w klasie EXC-2 wg PN-EN 1090-2						
A	Zmiana technologii produkcji.				20.01.2020	DTK
REWIZJA	IŁOŚĆ ZMIAN	OPIS REWIZJI			DATA	ROZ.
FORMAT A3	DATA:	NAZWA:	TOLERANCJE OGÓLNE	KRAWĘDZIE PRZEDMIOTU OBRABIANEGO:		
RYSOWAŁ:	05.12.2019	mgr inż. M. Sobas	PN-EN-22768 m, c			
SPRAWDZIŁ:	20.01.2020		WPS: AR-135-07-FW AR-135-08-FW AR-135-09-BW			
ZATWIERDZIŁ	NAZWA:		MASA: [kg]	158,26 kg	NR. RYSUNKU:	
SKALA:	AR31		ARKUSZ:	1 / 47	AR31-1	
1:20						