

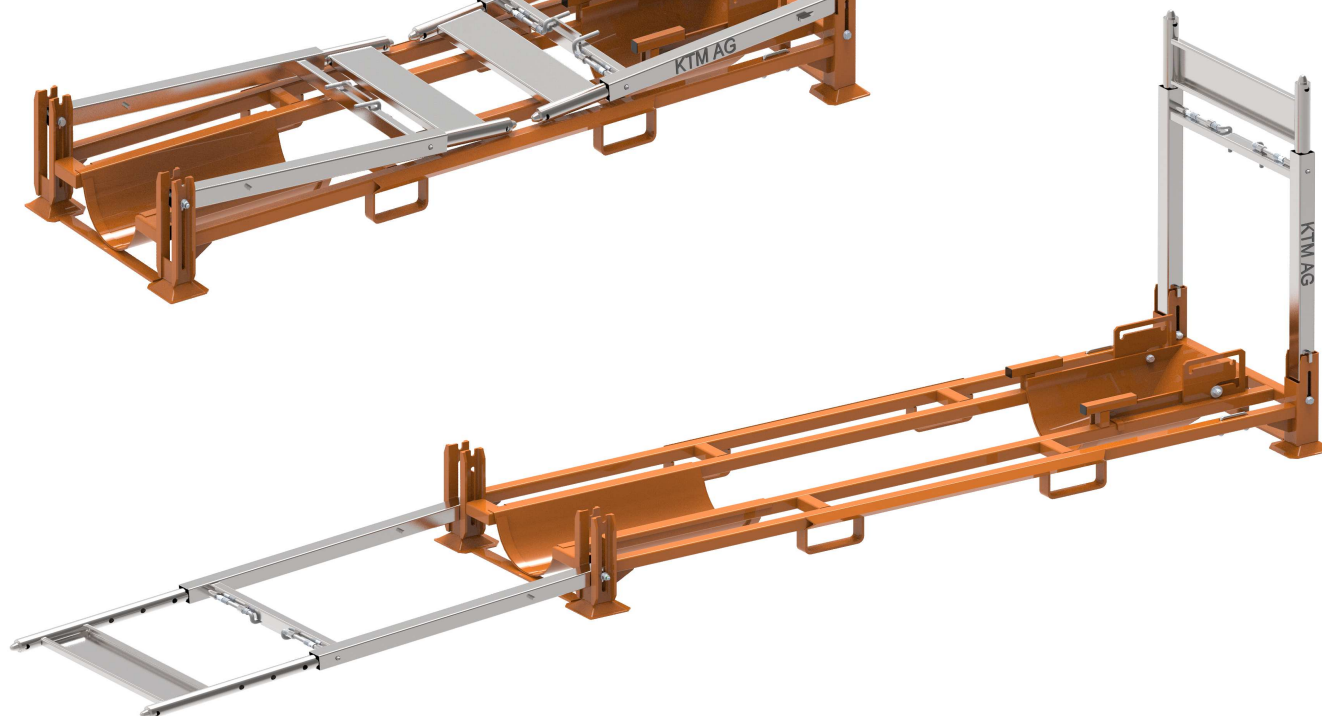

DIMENSIONS TOLERANCE	
TOLERANCE	+3 mm

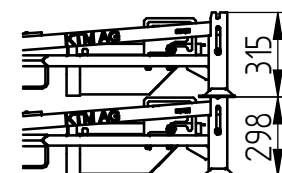
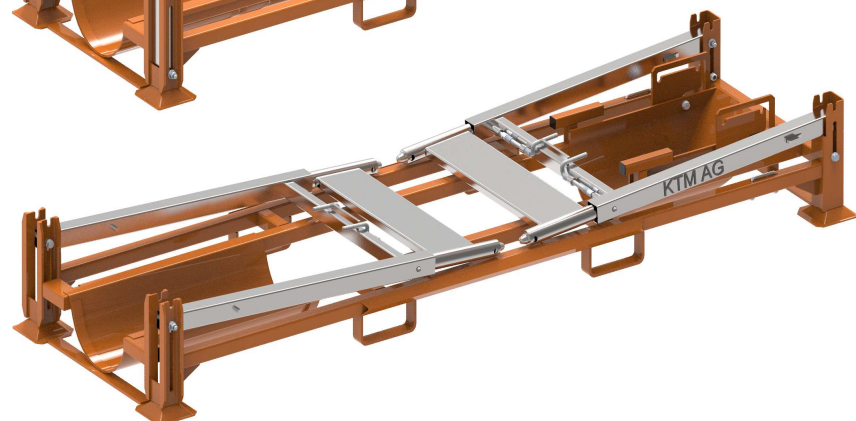
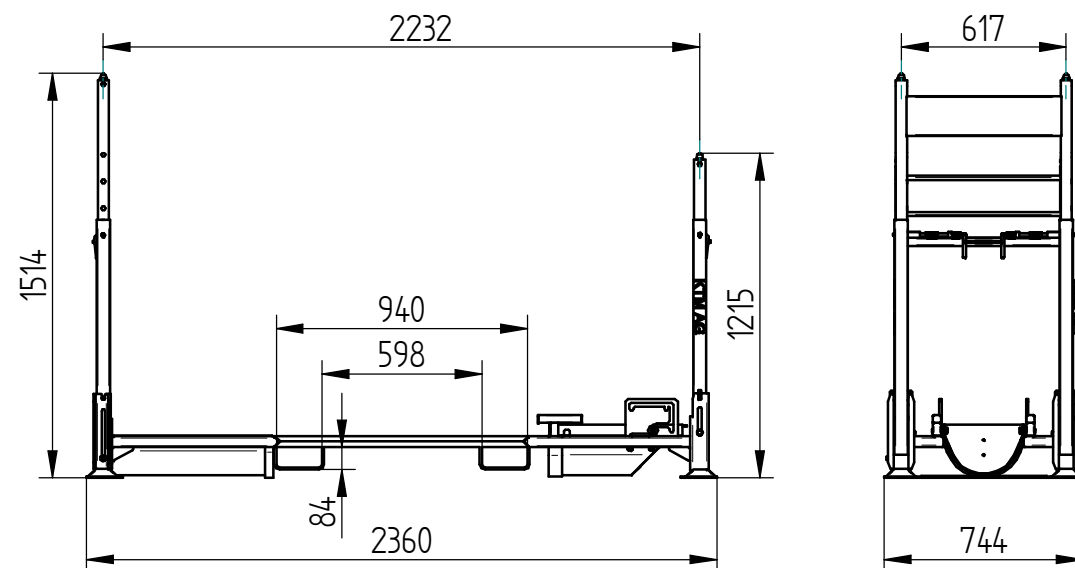
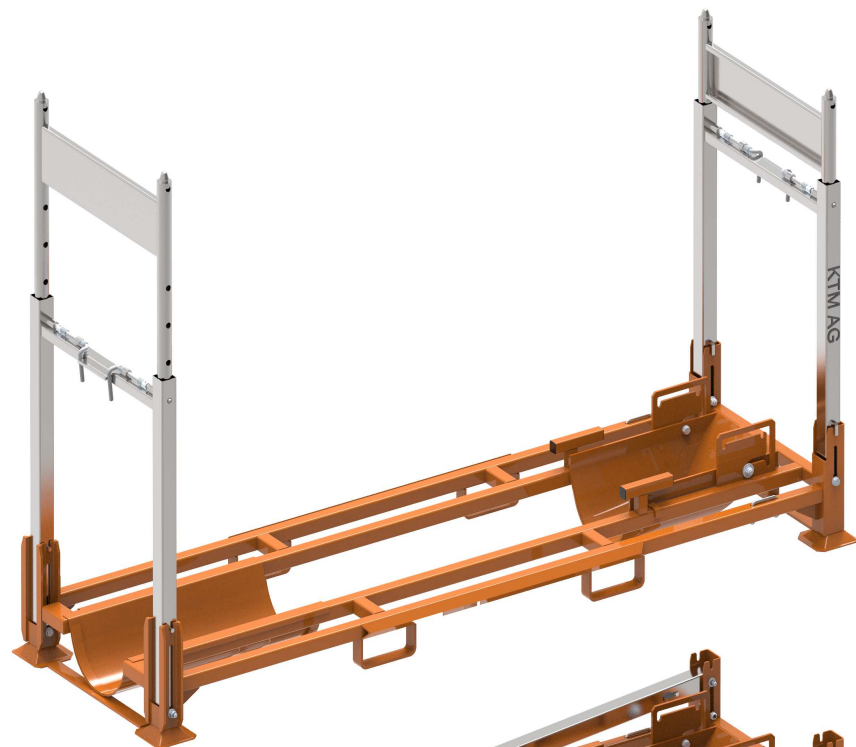

PRODUCT DATA SHEET				
DIMENSIONS	MAX LOAD	LEVELS	CAPACITY	OPTIMAL TRANSPORT
2360 X 744 X 1514	400 kg	5	1 motorcycle	180 pcs. / Z
F	Zmiana technologii spawania, dopracowanie detali			10.12.2018 DTK
REWIZJA	IŁOŚĆ ZMIAN	OPIS REWIZJI		DATA ROZ.
FORMAT A3	DATA:	NAZWA:	TOLERANCJE OGÓLNE	KRAWĘDZIE PRZEDMIOTU OBRABIANEGO:
RYSOWAŁ:	26.11.2018	mgr inż. S.Baran	PN-EN-22768 m, c	
SPRAWDZIŁ:	10.12.2018		WPS: AR-135-07-FW AR-135-08-FW AR-135-09-BW	
ZATWIERDZIŁ	NAZWA:		MASA: [kg]	NR. RYSUNKU:
SKALA:	K09 KTM/K7031006 Motorrad-Metalpalette		103 kg	K09-1
1:20			ARKUSZ:	1 / 50